

X *Over Sew* *413*
215
JUKI®

27
50
105
model **MH-38**

& SUBCLASSES

High Speed Flat Bed Double Needle Chainstitch
Industrial Sewing Machine

PARTS * BOOK

REVISION No. 5



TOKYO JUKI INDUSTRIAL CO., LTD.

From the library of: Superior Sewing Machine & Supply LLC

HOW TO MAKE USE OF THIS PARTS BOOK

1. This is a consolidated PARTS BOOK of Model MH-38 and subclasses.
2. This list is divided, as a principle, into various sections according to the functions of parts and also contains illustrations to assist you visually.
For example, if you want some parts for the OIL LUBRICATION MECHANISM COMPONENTS, just refer to the section on "OIL LUBRICATION MECHANISM COMPONENTS" etc.
3. The figures on the illustrations indicate the corresponding numbers on the BOOK.
4. On bits and pieces parts such as screws, etc. the illustration shows only a representative one and so for the required quantity of these parts, refer to the BOOK.
5. Parts marked with * on the "Ref. No." column, mean these parts are one complete assembly unit.
6. The parts under "Amt. Req." column circled by ○ are parts included in the one assembly unit which is marked with * just above these parts.
7. When placing your order, please specify your order by the assembly unit number marked with * under the "Ref. No." column.

FOR EXAMPLE

Ref. No.	Part No.	Description	Amt. Req.
*1	B-1111-111-0A0	name of part	1 Means one assembly unit
2	B-1111-111-000	" "	① Means this is included in the above B-1111-111-0A0 assembly unit. (This part can be sold as a single unit)

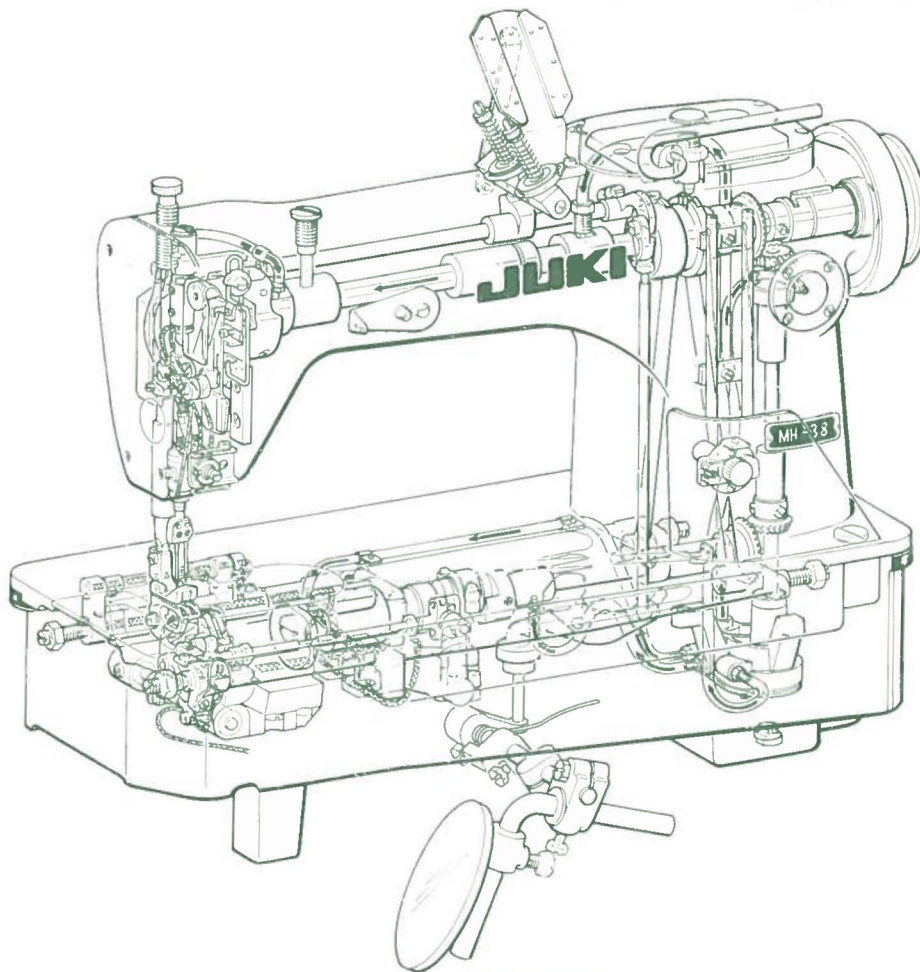

CONTENTS

1. FRAME, COVERS & TENSION PARTS COMPONENTS (1)	1
2. FRAME, COVERS & TENSION PARTS COMPONENTS (2)	2
3. FRAME, COVERS & TENSION PARTS COMPONENTS (3)	3
4. MAIN SHAFT & UPRIGHT SHAFT COMPONENTS	4
5. LOOPER ROCKER ROCK SHAFT & LOOPER ROCKER SHAFT COMPONENTS	5
6. FEED ROCKER SHAFT, FEED DRIVING SHAFT & CRANKSHAFT COMPONENTS	6
7. LOOPER DRIVE LEVER SHAFT COMPONENTS	7
8. NEEDLE BAR & COUNTERWEIGHT COMPONENTS	8
9. PRESSER BAR & KNEE LIFTER COMPONENTS	9
10. OIL LUBRICATION MECHANISM COMPONENTS	10
11. OIL RESERVOIR & KNEE PRESS PLATE COMPONENTS	11
12. EXCLUSIVE PARTS FOR MH-38-1 & MH-38-2	12
13. MH-38 GAUGE SETS	13
14. NUMERICAL INDEX OF PARTS	14

1. FRAME, COVERS & TENSION PARTS COMPONENTS (1)

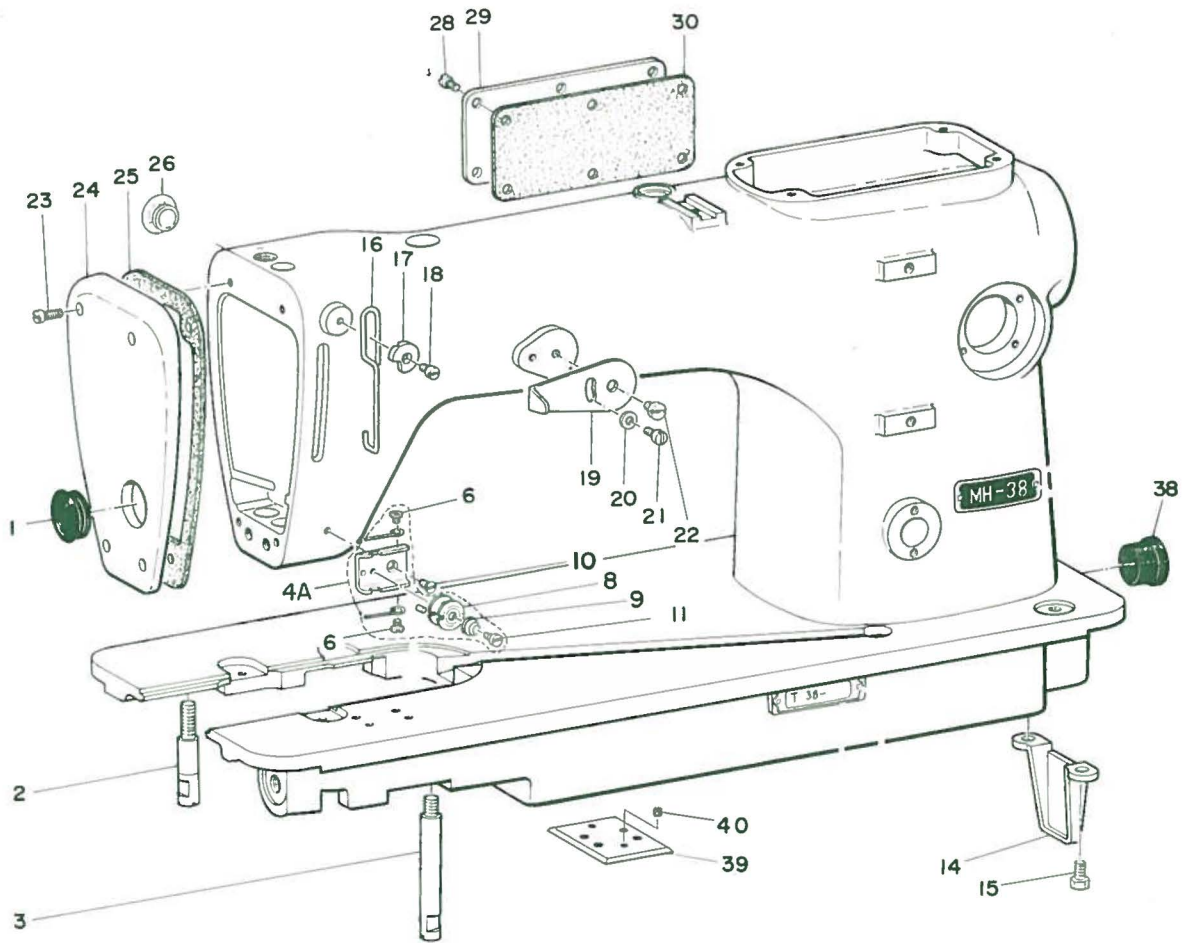

Ref. No.	Part No.	Description	Amt. Req.	Ref. No.	Part No.	Description	Amt. Req.
1	B-1180-541-000	Plug	1	19	B-1907-038-000	Frame thread eyelet	1
2	B-1123-038-000	Bed screw stud, rear	1	20	WP-0371016-SD	... Washer	1
3	B-1124-038-000	Bed screw stud, front	1	21	SS-7090710-SP	... Screw	1
*4A	B-1912-038-0A0	Take-up thread tension controller asm.	1	22	SD-0530221-SD	... Hinge screw	1
6	SS-6090420-SP	Screw	②	23	SS-4091010-SP	Screw	4
8	B-1914-038-000	Tension disc	②	24	B-1117-038-000	Head cover	1
9	B-3149-123-A00	Tension spring	①	25	B-1118-038-000	... Gasket	1
11	SD-0380551-SL	Hinge screw	①	26	B-1164-012-000	Rubber plug	1
10	SS-2090510-SP	Screw, controller	1	28	SS-4091010-SP	Screw	6
14	B-1106-122-000	Bed leg	1	29	B-1113-038-000A	Side plate	1
15	SS-9151160-CP	... Screw	2	30	B-1114-038-000A	... Gasket	1
16	B-1905-038-000	Take-up thread tension lever	1	38	B-1166-122-000	Plug	1
17	B-1906-038-000	... Washer	1	39	B-1111-038-000	Attachment clamp bed slide	1
18	SS-4091010-SP	... Screw	1	40	SS-8110310-SP	... Screw	2

2. ERAME, COVERS & TENSION PARTS COMPONENTS (2)

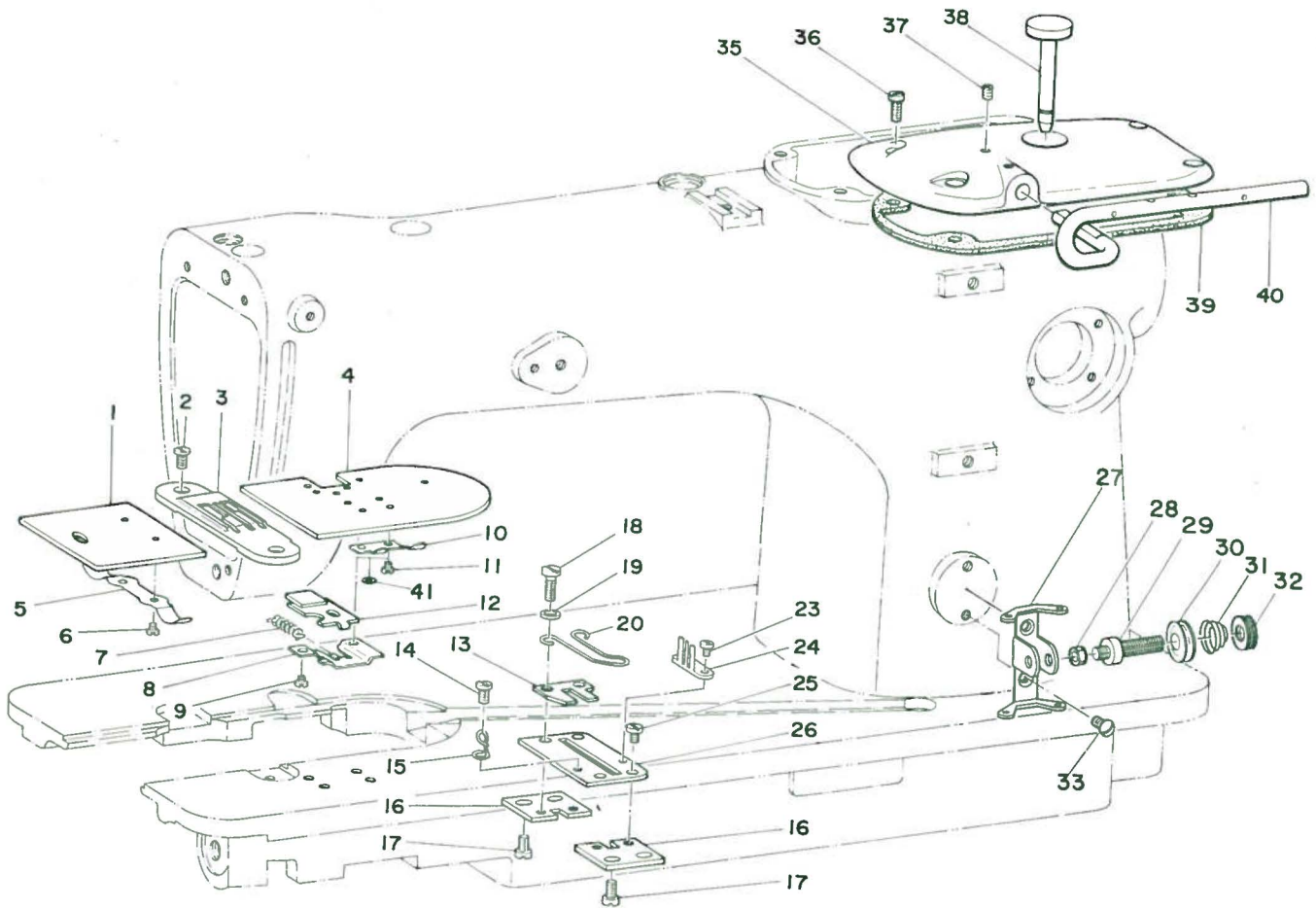

Ref. No.	Part No.	Description	Amt. Req.	Ref. No.	Part No.	Description	Amt. Req.
* 1	B-1104-038-0A0	Bed slide	1	20	B-2212-019-000	Cast-off wire (B)	1
5	B-1104-038-0A0	Bed slide spring	①	23	SS-7090520-SP	Screw	1
6	SS-6060210-SP	. . . Screw	②	24	B-2216-026-000	Auxiliary cast-off (E)	1
2	SS-2110920-TP	Screw	2	25	SS-7090510-SP	Screw	2
3	B-1103-038-D00	Throat plate	1	26	B-2208-038-000	Cast-off wire support bracket	1
4	B-1106-038-000	Looper thread take-up cover	①	*	B-2405-038-0A0	Looper thread tension post pin asm.	1
	B-1106-038-B00	Looper thread take-up cover (for 3/8", 5/16", 1/2")	(1)	27	B-2405-038-000	Looper thread tension guide	①
7	B-1110-038-000	Take-up cover latch spring	1	28	NS-6110-310-SP	Looper thread tension post nut	②
8	B-1109-038-000	Take-up cover latch support	1	29	B-3219-232-000	Looper thread tension post	①
9	SS-6080320-SP	. . . Screw	2	30	B-3214-047-000	. . . Disk	④
10	B-1107-038-000	Take-up cover spring (C)	1	31	B-3168-555-B00	. . . Spring	②
11	SS-6080320-SP	. . . Screw	2	32	B-3216-047-000	. . . Nut	②
41	WP-0330500-MB	. . . Washer	2	33	SS-2090510-SP	Screw, for tension guide	②
12	B-1108-038-000	Take-up cover latch	1	35	B-1115-038-000	Top cover	1
13	B-2213-038-000	Cast-off wire (B) support, upper	1	36	SS-7111120-SP	. . . Screw	4
14	SS-7090520-SP	Screw	1	37	SS-8110750-SP	Screw	2
15	B-2213-019-000	Take-up eyelet (C)	1	38	B-1618-038-0A0	Thumb stud asm.	1
16	B-2207-038-000	Cast-off wire (B) support, lower	2	39	B-1116-038-000	Top cover gasket	1
17	SS-7090710-SP	. . . Screw	4	40	B-2401-038-000	Looper thread eyelet	1
18	SS-7091110-SP	Screw	2				
19	WP-0371016-SD	Washer	2				

3. FRAME, COVERS & TENSION PARTS COMPONENTS (3)

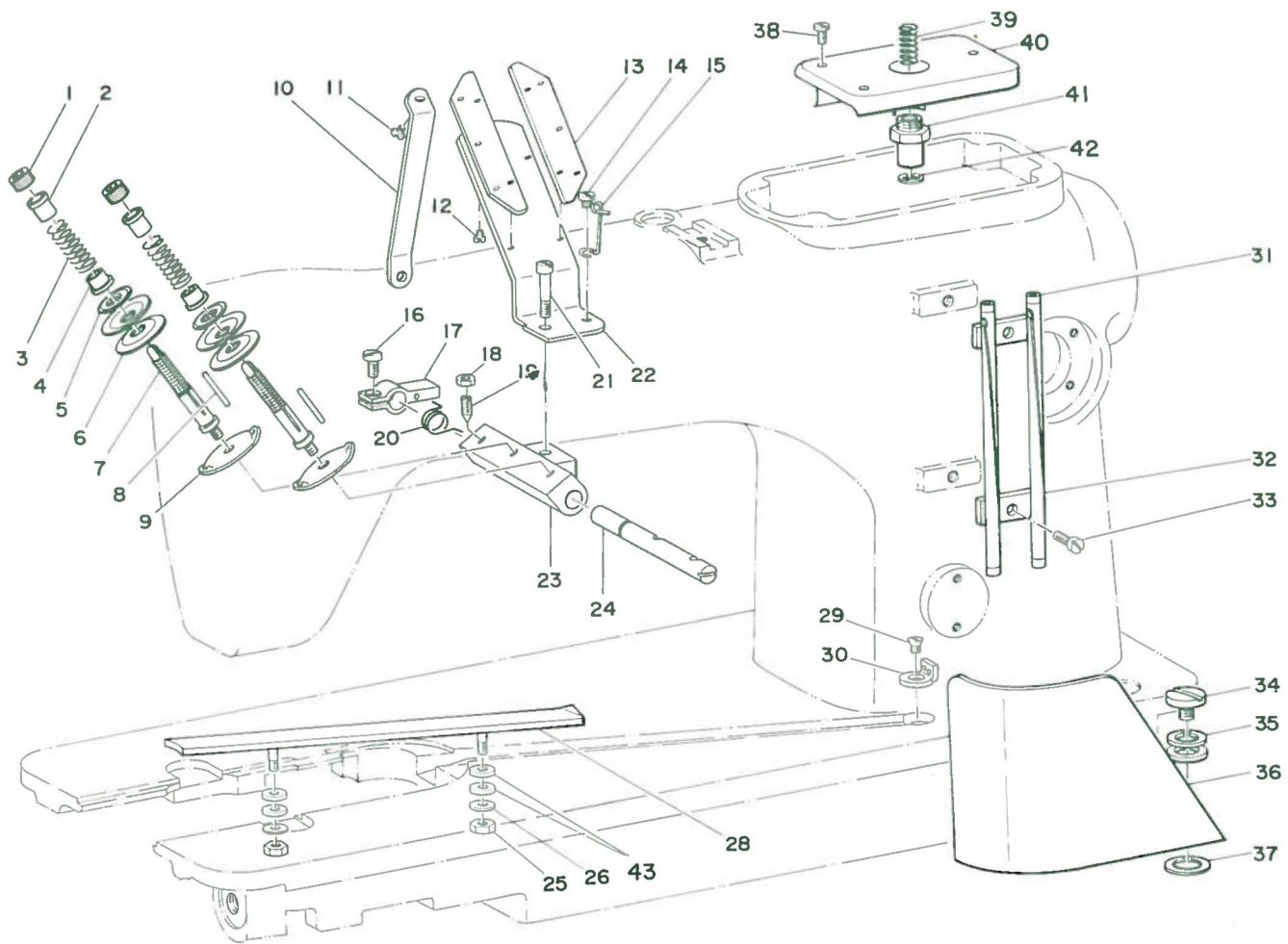

Ref. No.	Part No.	Description	Amt. Req.	Ref. No.	Part No.	Description	Amt. Req.
23	B-2301-038-000	Needle thread tension bracket	1	17	B-2318-038-000	Tension releasing shaft crank	1
24	B-2303-038-000	Tension releasing shaft	1	16	SS-6111040-SP	Screw	1
1	B-2314-019-000	Tension post nut	2	20	B-2319-038-000	Take-up spring	1
2	B-2312-019-000	Tension spring bushing (A)	2	21	SS-4622340-SP	Screw	1
3	B-2311-019-000	Tension spring	2	25	NS-6090310-SP	Nut	2
4	B-2313-019-000	Tension spring bushing (B)	2	26	WP-0371016-SP	Washer	2
5	B-3132-012-000	Tension releasing disc	2	28	B-2202-038-0A0	Looper thread tube asm.	1
6	B-3126-012-000	Tension disc	4	29	SS-2090510-SP	Screw	1
7	B-2307-019-000	Tension post	2	30	B-2201-038-000	Looper thread eyelet	1
8	B-2310-019-000	Tension releasing pin	2	31	B-2418-019-000	Looper thread tube cap	1
9	B-2306-019-000	Tension thread guide	2	32	B-2402-038-000	Looper thread tube (B)	1
18	NS-6110310-SP	Nut	1	33	SS-7120910-SP	Screw	2
19	SS-8111160-SP	Screw	1	34	SD-0980401-SD	Hinge screw	1
22	B-2320-038-000	Needle thread guide bracket	1	35	A-1632-007-000	Washer	1
13	B-2402-019-000	Thread guide	2	36	B-1119-038-000	Looper thread cover	1
12	SS-5060410-SP	. . . Screw	4	37	WP-0612056-SD	. . . Washer	1
10	B-2324-038-000	Thread guide bracket support	1	38	SS-7090510-SP	Screw, for top cover oil shield	3
11	SS-7090410-SP	. . . Screw	1	39	B-1622-038-000	Spring, for thumb stud	1
14	SS-7090510-SP	Screw	1	40	B-1121-038-0C0	Top cover oil shield stud	1
15	B-2421-019-000	Needle thread eyelet	1	41	B-1621-038-000	Bushing, for thumb stud	1
				42	RE-0500000-K0	Snap ring	1
				43	B-2204-038-000	Gasket	4

4. MAIN SHAFT & UPRIGHT SHAFT COMPONENTS

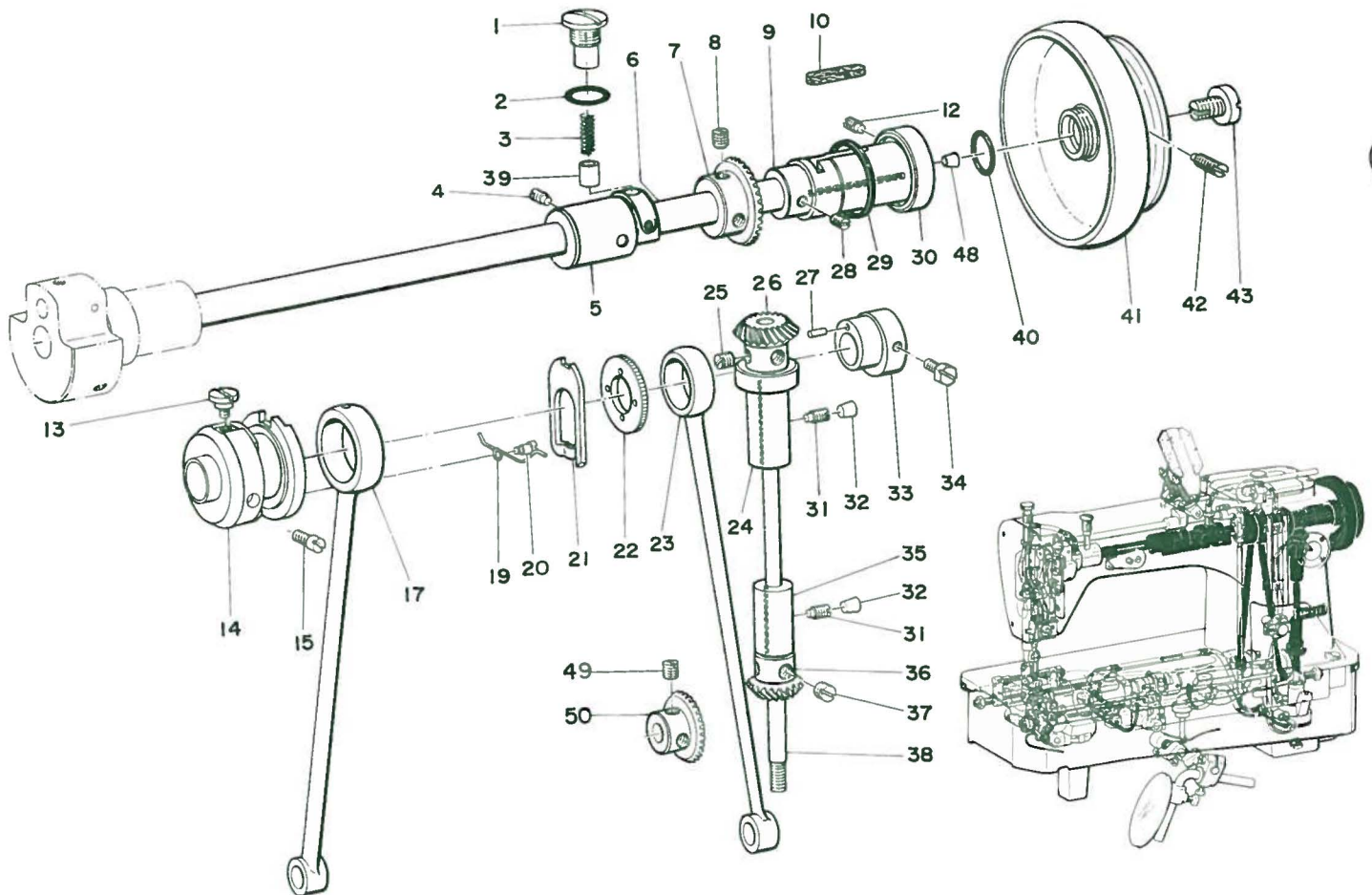

Ref. No.	Part No.	Description	Amt. Req.	Ref. No.	Part No.	Description	Amt. Req.
1	B-3536-155-000	Plunger thrust screw	1	26	B-1306-012-000	Pinion	1
2	RO-1542401-00	. . . Rubber ring	1	27	B-1620-155-000	Ratchet connecting pin	1
3	B-1214-038-000	Plunger spring	1	29	B-1235-122-000	Gasket	1
39	B-3534-155-000	Plunger	1	30	B-1204-122-000	Main shaft bushing, rear	1
4	SS-8151150-SP	Screw, for center bushing	1	12	SS-8151150-SP	Screw	1
5	B-1203-038-000	Main shaft bushing, center	1	31	SS-8151150-SP	Screw	2
6	B-1201-038-000B	Main shaft	1	32	TA-0690801-RO	Plug	2
7	B-1305-012-000	Gear	1	33	B-1706-038-000	Feed drive eccentric	1
8	SS-8660810-TP	. . . Screw	2	34	SS-8150710-SP	. . . Screw	2
9	CS-1471012-SH	Main shaft thrust collar	1	35	B-1303-122-000	Upright shaft bushing, lower	1
28	SS-8150410-SP	Screw	2	36	B-1306-012-000	Mitre gear	1
10	B-1218-012-000	Oil felt	1	37	SS-8660810-TP	Screw	2
12	SS-8151150-SP	Main shaft bushing, rear screw	1	38	B-1301-038-000	Upright shaft	1
*14	B-1610-038-0A0	Feed eccentric asm.	1	48	TA-0570601-M0	Plug	1
13	SD-0700351-SD	Feed regulating screw (B)	①	40	RO-1331701-00	Rubber ring	1
15	SS-8611430-SP	. . . Screw	②	41	B-1217-092-000	Hand wheel	1
17	B-1609-038-000	Feed lift driving rod	1	42	SS-8152080-SP	. . . Screw	2
19	B-1624-552-000	Torsion spring	1	43	B-1233-012-000	. . . End screw	1
20	SD-0260271-SP	. . . Screw	1	50	B-1307-038-000	Mitre gear, large	1
21	B-1623-552-000	Ratchet pawl	1	49	SS-8660810-TP	. . . Screw	2
22	B-1616-038-000	Ratchet gear	1				
23	B-1705-038-000	Feed driving rod	1				
24	B-1302-038-000	Upright shaft bushing, upper	1				
25	SS-8660810-TP	Screw	2				

5. LOOPER ROCKER ROCK SHAFT & LOOPER ROCKER SHAFT COMPONENTS

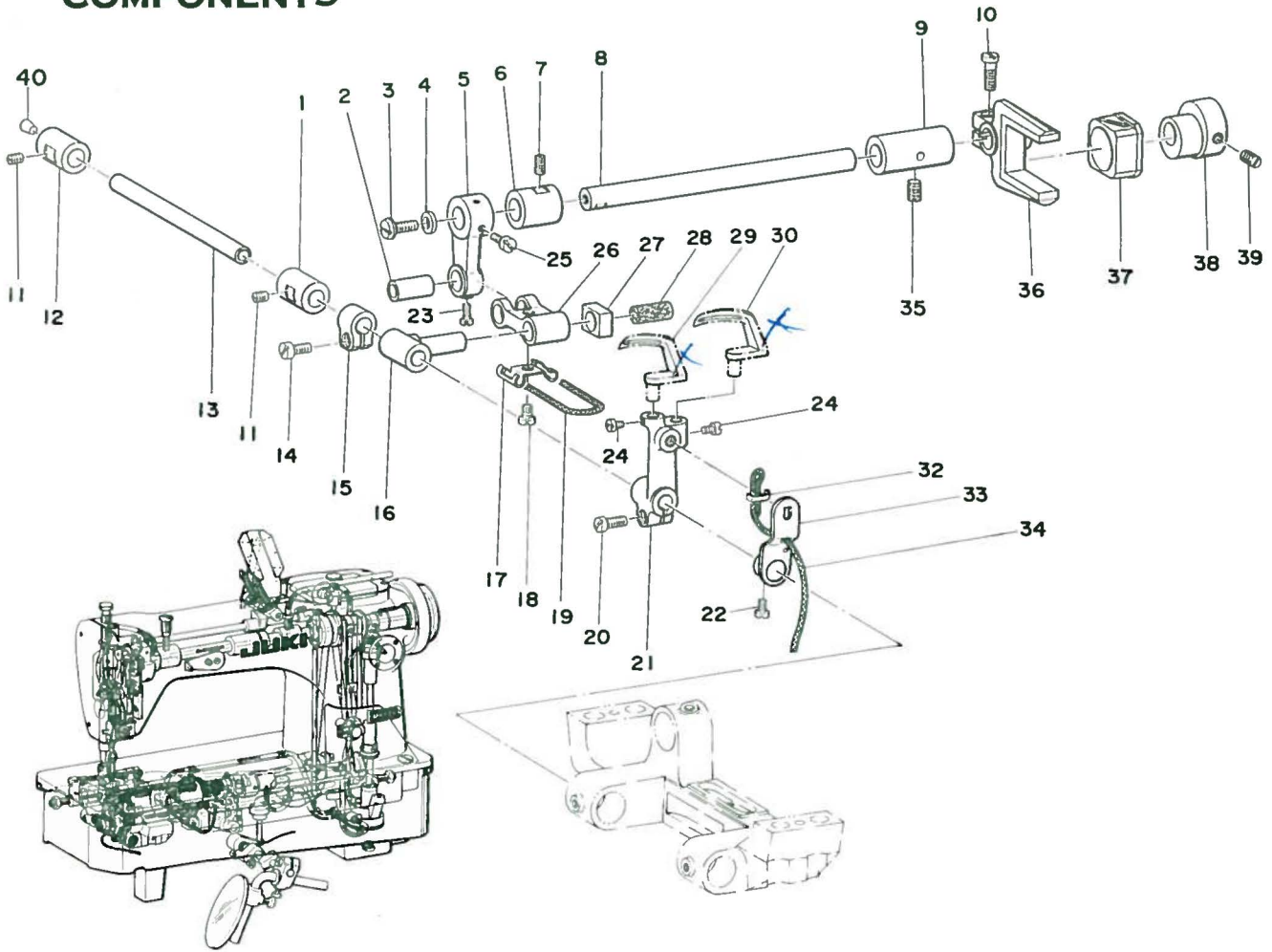

Ref. No.	Part No.	Description	Amt. Req.	Ref. No.	Part No.	Description	Amt. Req.
1	B-2004-038-000	Looper rocker shaft bushing, front	1	20	SS-7111110-TP	Clamp screw	1
2	B-2107-038-000	Looper rock shaft arm pin	1	21	B-2006-038-000	Looper rocker	1
3	SS-6121050-SP	End screw	2	23	B-2109-038-000	Screw	1
4	B-2113-038-000	Washer	2	24	SS-7110540-SP	Screw	2
5	B-2108-038-000	Looper rocker rock shaft arm	1	26	B-2104-038-000	Looper rocker shaft drive link	1
25	SS-7110710-SP	Screw	2	27	B-1411-019-000	Slide block	1
6	B-2111-038-000	Looper rocker rock shaft bushing, front	1	28	B-1418-019-000	Oil felt	1
7	SS-8110510-SP	. . . Screw	1	32	B-1419-026-000	Oil wick holder	1
8	B-2110-038-000	Looper rocker rock shaft	1	33	B-2011-038-0A0	Oil wick bracket asm.	1
9	B-2112-038-000	. . . Bushing, rear	1	22	SS-7090520-SP	Screw	1
36	B-2116-038-000	Looper rocker rock shaft fork	1	34	CQ-3030000-00	Oil wick	1
10	SS-7111110-TP	Clamp screw	2	35	SS-8151150-SP	Screw	1
11	SS-8110510-SP	Screw	2	37	B-2115-038-000	. . . Sleeve	1
12	B-2005-038-000	Looper rocker shaft bushing, rear	1	38	B-2114-038-000	. . . Eccentric	1
13	B-2002-038-000	Looper rocker shaft	1	39	SS-8150710-SP Screw	2
14	SS-7111110-TP	Screw	1	40	TA-0500601-M0	Plug	2
15	B-2103-038-000	Looper rocker shaft thrust collar	1				
16	B-2101-038-000	Looper rocker shaft connection	1				
17	B-2105-038-000	Oil wick holder	1				
18	SS-7090510-SP	. . . Screw	1				
19	CQ-3030000-00	Oil wick	1				

6. FEED ROCKER SHAFT, FEED DRIVING SHAFT & CRANKSHAFT COMPONENTS

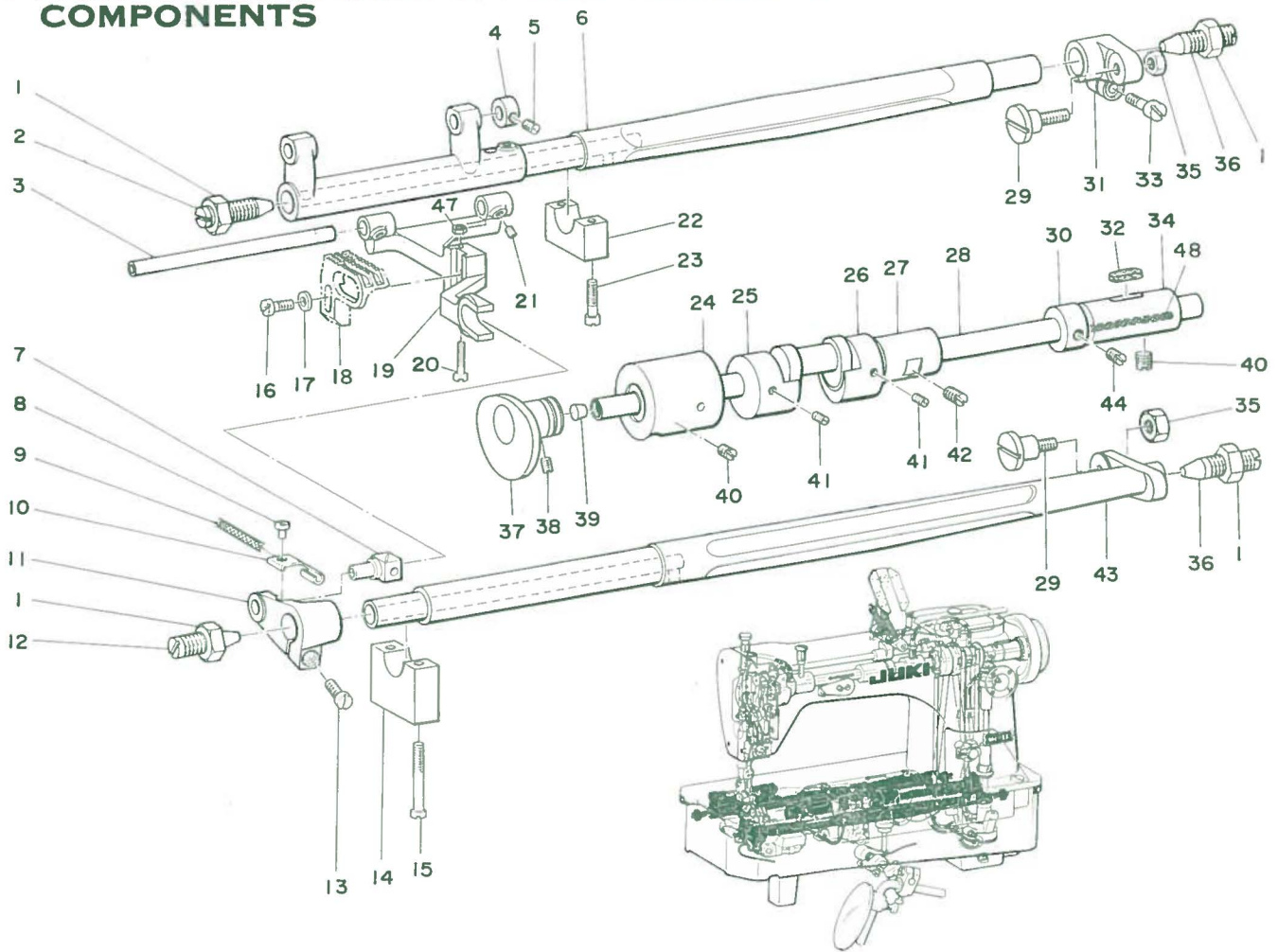

Ref. No.	Part No.	Description	Amt. Req.	Ref. No.	Part No.	Description	Amt. Req.
1	NS-6740510-SP	Nut	4	41	SS-8620850-SP	Screw	2
2	B-1113-012-000	End screw	1	26	B-1810-038-000	Crank (B)	1
3	B-1603-038-000	Feed bar shaft	1	41	SS-8620850-SP	. . . Screw	2
4	CS-0640863-SH	. . . Thrust collar	1	27	B-1803-038-000	Crankshaft bushing, center	1
5	SS-8110510-SP Screw	2	28	B-1801-038-000	Crankshaft	1
6	B-1601-038-000	Feed rocker shaft	1	29	SD-1020916-SP	Hinge screw	2
7	B-1707-012-0A0	Slide block & stud asm.	1	30	CS-1031219-SH	Crankshaft thrust collar	1
8	SS-7080510-SP	Screw	1	44	SS-8660610-TP	Screw	2
9	CQ-3030000-00	Oil wick	1	31	B-1607-038-000	Feed rocker shaft crank	1
10	B-1708-038-000	Oil wick holder	1	33	SS-6111620-SP	Clamp screw	1
11	B-1702-038-000	Feed driving shaft crank	1	32	B-1806-038-000	Crankshaft rear bushing oil felt	1
13	SS-7111410-SP	Clamp screw	1	34	B-1804-038-000	Crankshaft bushing, rear	1
12	B-1134-038-000	End screw, small	1	35	NS-6680410-SP	Nut	2
14	B-1707-038-000	Support block	1	36	B-1112-038-000	End screw, large	2
15	SS-6092420-SP	. . . Screw	2	37	B-2206-038-000	Looper drive eccentric	1
16	SS-7111410-SP	Screw	1	38	SS-8110320-SP	. . . Screw	1
17	WP-0480856-SP	Washer	1	39	TA-0370301-M0	Oil seal plug	1
18	B-1605-038-D00	Feed dog (3/16")	1	40	SS-8151150-SP	Screw	2
19	B-1602-038-000	Feed bar	1	42	SS-8150310-SP	Screw	1
20	SS-6081810-SP	Screw	1	43	B-1701-038-000	Feed driving shaft	1
21	SS-8110510-SP	Screw	2	47	NS-6080210-SP	Adjusting nut	1
22	B-1606-038-000	Support block	1	48	CQ-3030000-00	Oil wick	1
23	SS-6091510-SP	. . . Screw	2				
24	B-1802-038-000	Crankshaft bushing, front	1				
25	B-1809-038-000	Crank (A)	1				

7. LOOPER DRIVE LEVER SHAFT COMPONENTS

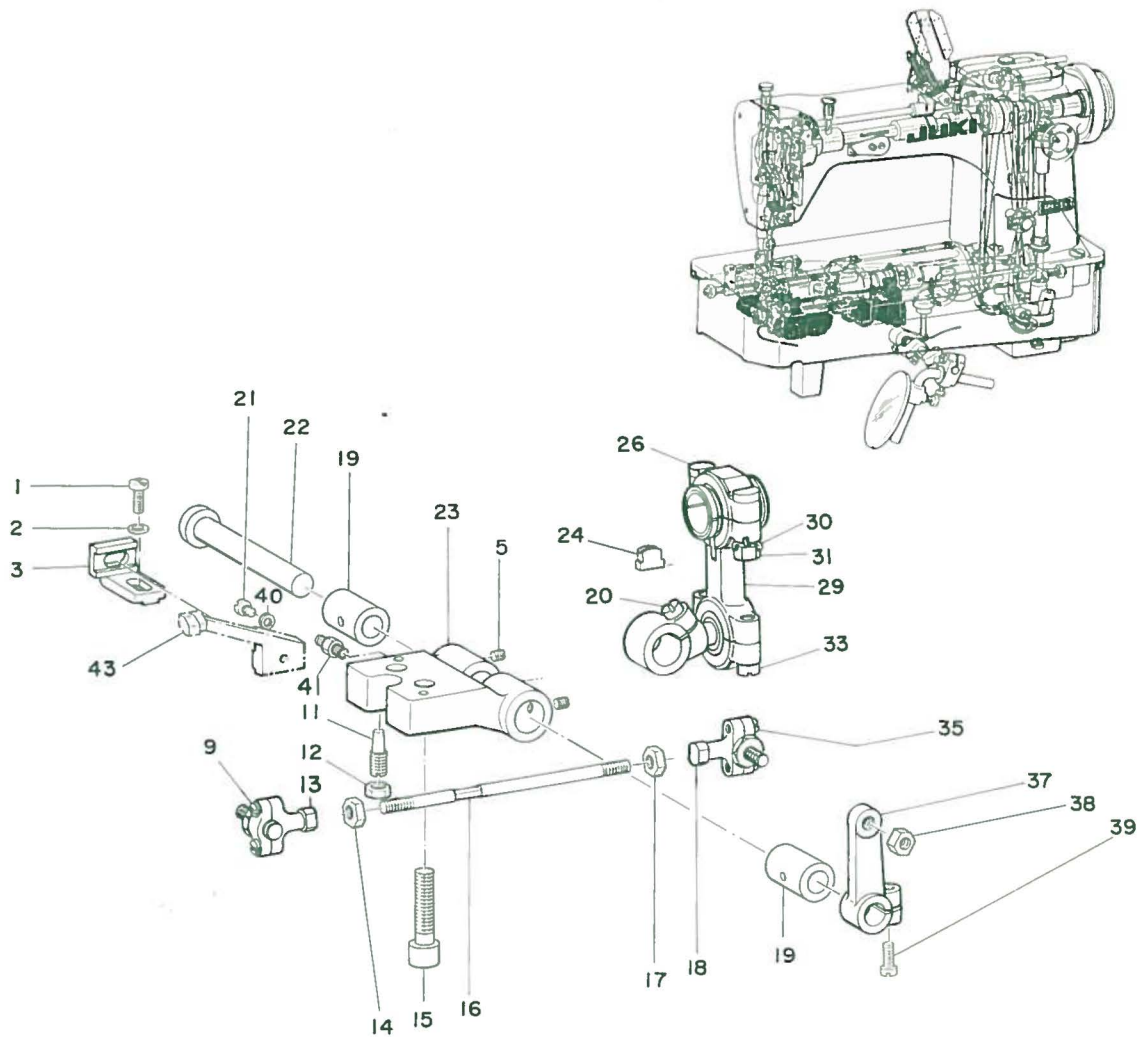

Ref. No.	Part No.	Description	Amt. Req.	Ref. No.	Part No.	Description	Amt. Req.
1	SS-7151210-SP	Screw	1	21	SS-9111010-SP	Screw	1
2	WP-0621016-SD	Washer	1	22	B-2021-038-000	Looper drive lever shaft	1
3	B-2118-038-000	Needle guard bracket	1	23	B-2020-038-000	. . . Bearing bracket	1
11	B-2032-038-000	Oil adjusting valve	1	24	B-2026-038-000	Rotation stop	1
12	NS-6150310-SP	. . . Nut	1	*29	B-2027-038-0A0	Crank connecting rod asm.	1
*13	B-2014-038-0A0	Ball joint, right (front) asm.	1	20	SS-7111110-TP	. . . Screw	①
9	SS-4091010-SP	Screw	②	26	B-2036-038-000	Clamp screw	②
5	SS-8110510-SP	Screw	2	31	NS-6110402-SP	Nut	②
14	B-2017-038-000	Nut	1	33	SS-7111310-SP	. . . Clamp screw	②
15	SM-6081542-CP	Screw	2	30	B-2030-038-000	Washer	①
16	B-2016-038-000	Looper connecting rod	1	37	B-2023-038-000	Looper drive lever shaft crank	1
17	NM-6050540-SP	Nut	1	39	SS-7111110-TP	Clamp screw	1
*18	B-2018-038-0A0	Ball joint, left (rear) asm.	1	38	NS-6150310-SP	Nut	1
35	SS-4091010-SP	. . . Screw	②	40	WP-0480856-SP	Washer	1
19	B-2022-038-000	Looper rocker shaft bushing	2	41	SQ-1110402-MZ	Connecting screw	1
				43	B-2117-038-000	Needle guard (1/8"~1/4")	1
					B-2117-038-K00 (5/16"~1/2")	(1)

8. NEEDLE BAR & COUNTERWEIGHT COMPONENTS

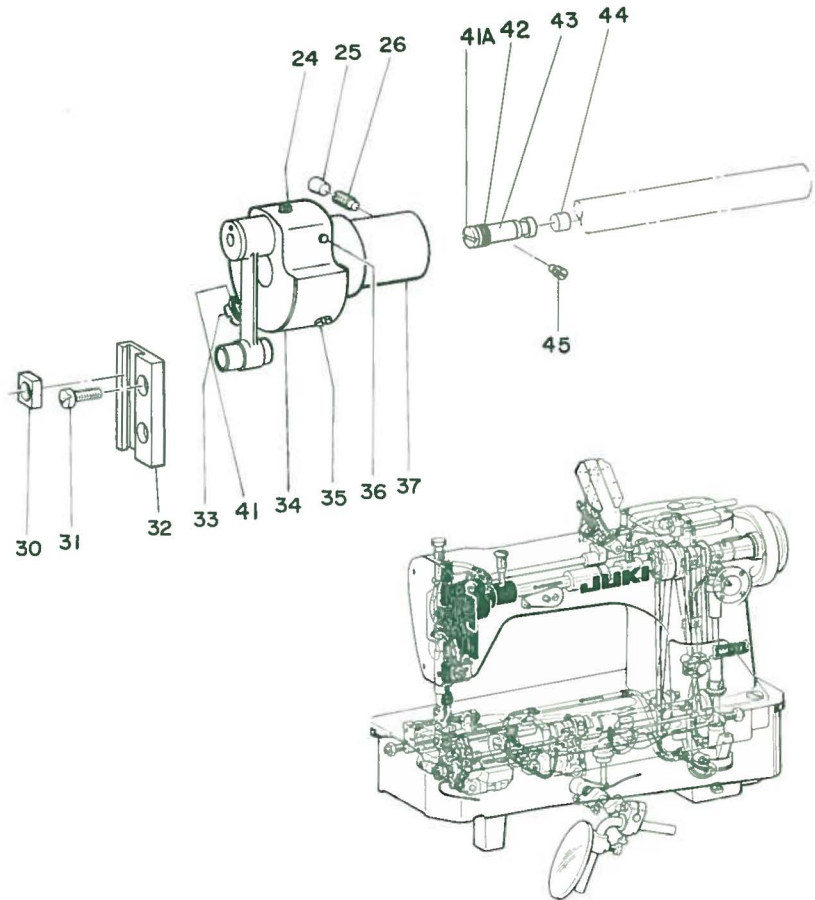
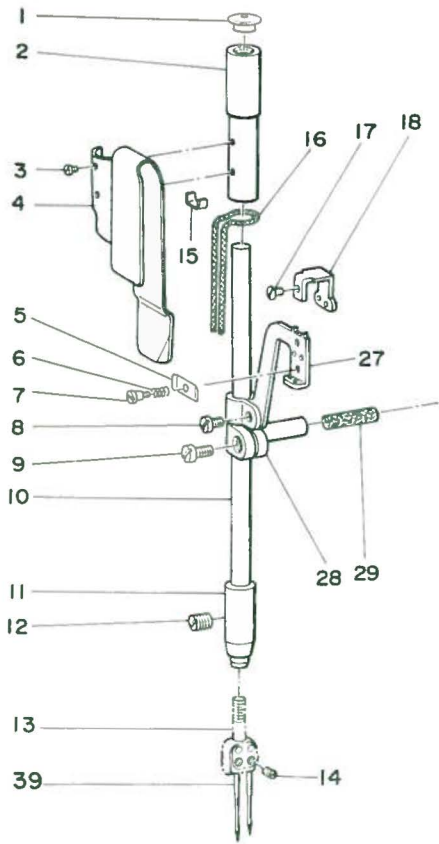

Ref. No.	Part No.	Description	Amt. Req.	Ref. No.	Part No.	Description	Amt. Req.
1	B-1405-012-000	Cap screw	1	28	B-1409-019-000	Needle bar connection asm.	1
2	B-1402-038-000	Needle bar bushing, upper	1	9	SS-7090910-SP	Clamp screw	1
3	SS-5060310-SP	Screw	2	29	B-1418-019-000	. . . Roller felt	1
4	B-1909-038-000	Take-up oil splasher	1	30	B-1411-019-000	. . . Slide block	1
5	B-1908-019-000	Take-up tension plate	1	31	SS-7120910-SP Screw	2
6	B-1910-019-000	Take-up tension spring	1	32	B-1412-038-000 Guide	1
7	SD-0280401-SL	. . . Hinge screw	1	*34	B-1211-038-OA0	Counterweight asm.	1
8	SS-6090670-SP	Clamp screw	1	24	SS-8150710-SP	Screw	②
10	B-1401-038-000	Needle bar	1	33	SS-7681650-TP	Screw (A)	①
11	B-1403-155-000	Needle bar bushing, lower	1	35	SS-8681650-TP	. . . Screw (B)	①
12	SS-8150310-SP	. . . Screw	1	36	PT-0252200-S0	. . . Tapered pin	①
13	B-1406-019-000	Needle clamp	1	41	RO-0442401-00	. . . Rubber ring	①
14	SS-8110310-SP	Clamp screw	2	37	B-1204-038-000A	Arm shaft bushing, front	1
15	B-1419-026-000	Oil wick holder	1	39	MTV-700B1600	Needle (TV X 6)	2
16	CQ-3030000-00	Oil wick	1	45	B-1224-552-000	Main shaft oil adjusting pin	1
17	SS-3060410-SP	Screw	1				
18	B-1906-019-000	Take-up thread eyelet	1				
41A	B-1213-552-000	Oil adjusting pin	1				
42	RO-0291801-00	. . . Rubber ring	1				
43	B-1215-552-000	. . . Collar	1				
44	B-1226-552-000	. . . Felt	1				
45	B-1224-552-000	. . . Screw	1				
25	TA-0690801-R0	Plug	1				
26	SS-8151150-SP	Screw	1				
27	B-1901-038-000	Link take-up	1				

9. PRESSER BAR & KNEE LIFTER COMPONENTS

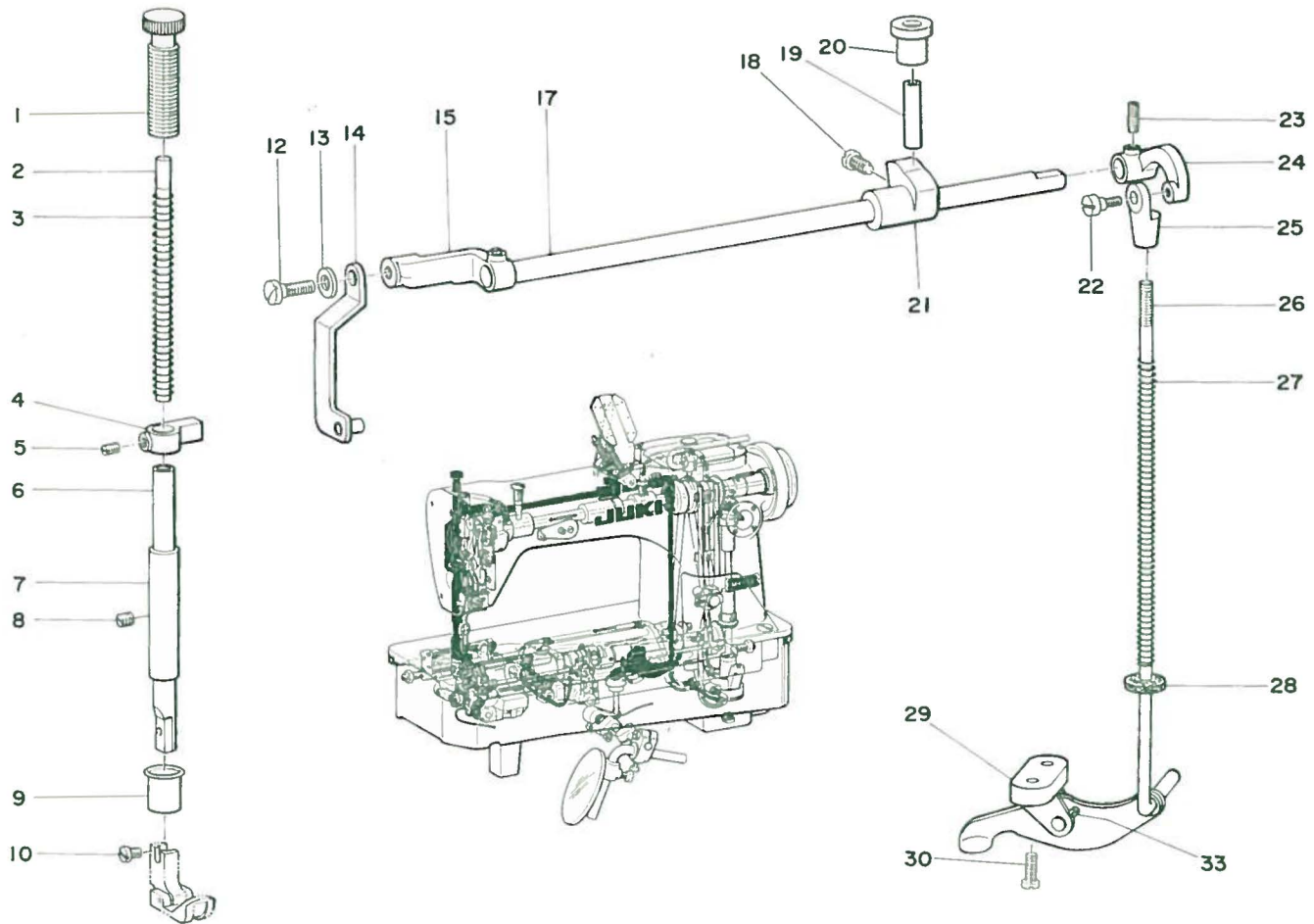

Ref. No.	Part No.	Description	Amt. Req.	Ref. No.	Part No.	Description	Amt. Req.
1	B-1509-581-000 ✓	Presser spring regulator	1	19	B-2317-038-000	Thread releasing pin	1
2	B-1510-581-000 ✓	Presser spring rod	1	20	B-2316-038-000	. . . Thumb bushing	1
3	B-1505-038-000 ✓	Presser spring	1	21	B-2315-038-000	Thread releasing cam asm.	1
4	B-1506-038-000	Presser bar connection & guide asm.	1	18	SS-3150710-SP	Screw	1
5	SS-8110510-SP	. . . Screw	1	22	SD-0600401-SP	Screw	1
6	B-1501-038-000	Presser bar	1	23	SS-7110910-SP	Screw	1
7	B-1502-038-000	Presser bar bushing, lower	1	24	B-3407-155-000	Lifting rock shaft crank, rear	1
8	SS-8150310-SP	. . . Screw	1	25	B-3416-012-000	Connecting rod joint	1
9	B-1512-155-000	Rubber cup	1	26	B-3409-038-000	Lifting rock shaft connecting rod	1
10	SS-7091110-SP ✓	Screw	1	27	B-3404-122-000	. . . Spring	1
11	B-1509-038-DA0	Presser foot assembly (3/16")	1	28	WP-0612516-SD Washer	1
12	SD-0600301-SP	Screw	1	*29	B-3401-122-0A0 ✓	Bell crank bracket asm.	1
13	WP-0651056-SD	Washer	1	33	SS-8080950-SP	. . . Pin	①
14	B-1507-038-0A0	Lifting rock shaft link asm.	1	30	SS-7120910-SP ✓	. . . Screw	2
15	B-3406-125-000	Lifting rock shaft, crank, front asm.	1				

10. OIL LUBRICATION MECHANISM COMPONENTS

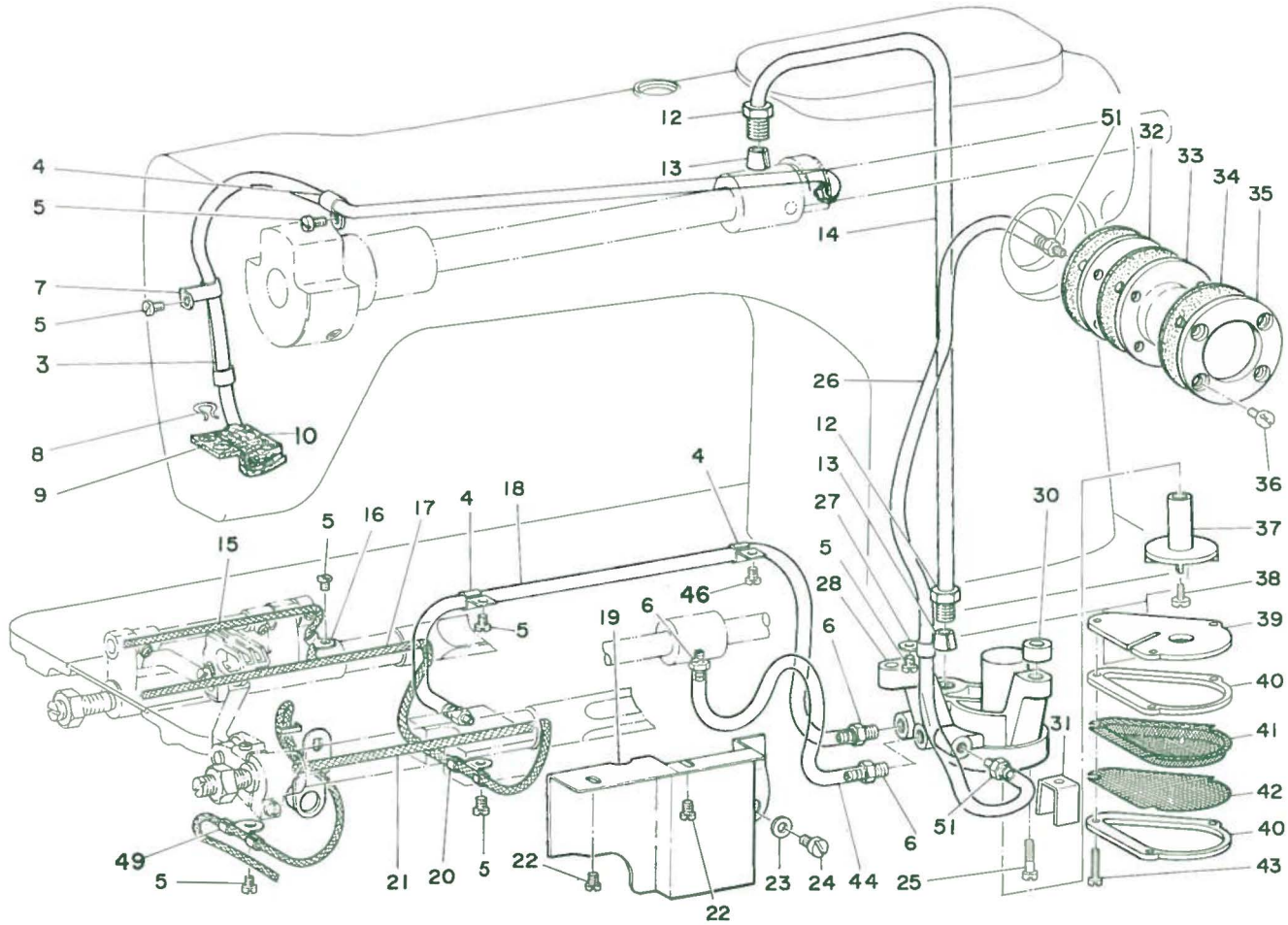

Ref. No.	Part No.	Description	Amt. Req.	Ref. No.	Part No.	Description	Amt. Req.
3	BP-3000000-00	Oil return tube	1	25	SS-6122030-SP	Screw	3
4	B-3536-122-000	Oil tube holder	3	26	BP-3000000-00	Oil tube (C)	1
5	SS-7090510-SP	. . . Screw	7	27	B-3517-038-000	. . . Holder	1
6	SQ-1150451-MZ	Oil tube connecting screw	3	28	B-3501-122-000	Lubricating oil pump frame	1
7	B-3527-038-000	Oil tube holder	1	30	B-3508-038-000	. . . Spacing collar	3
10	B-3526-226-000	Nozzle clamp	1	31	B-3545-122-000	. . . Oil splasher	1
9	B-3528-555-000	Oil return felt	1	32	B-3531-155-0A0	Oil sight window base	1
8	B-3529-226-000	. . . Holder	1	33	B-3520-038-000	Oil sight window	1
11	BP-3000000-00	Oil tube (D)	1	34	B-3523-038-000	. . . Gasket	3
12	B-3512-122-000	Oil pipe clamping sleeve nut	2	35	B-3521-038-000	. . . Frame	1
13	B-3511-122-000	Oil pipe clamping sleeve	2	36	SS-7091410-SP Screw	4
14	B-3509-038-000A	Arm shaft oil pipe	1	37	B-3507-122-000	Lubricating oil pump impeller	1
15	CQ-3030000-00	Feed bar shaft oil wick	1	38	SS-6080610-TP	. . . Screw	1
17	CQ-3030000-00	Feed rock shaft oil wick	1	39	B-3502-122-000	Lubricating oil pump cover	1
18	BP-3000000000	Oil tube (B)	1	40	B-3503-122-000	Lubricating oil pump frame (A)	2
19	B-2035-038-000	Oil splasher	1	41	B-3504-155-000	Filter screen	1
20	B-3537-122-000	Oil wick holder (B)	2	42	B-3506-125-000	Filter net	1
21	CQ-3030000-00	Feed driving shaft oil wick	1	43	SS-6081210-SP	Screw	3
22	SS-7090520-SP	Screw	2	44	BP-3000000-00	Oil tube	1
23	WP-0621016-SD	Washer	1	51	SQ-1110402-MZ	Oil tube connecting screw	4
24	SS-5150540-SP	Screw	1				

11 OIL RESERVOIR & KNEE PRESS PLATE COMPONENTS

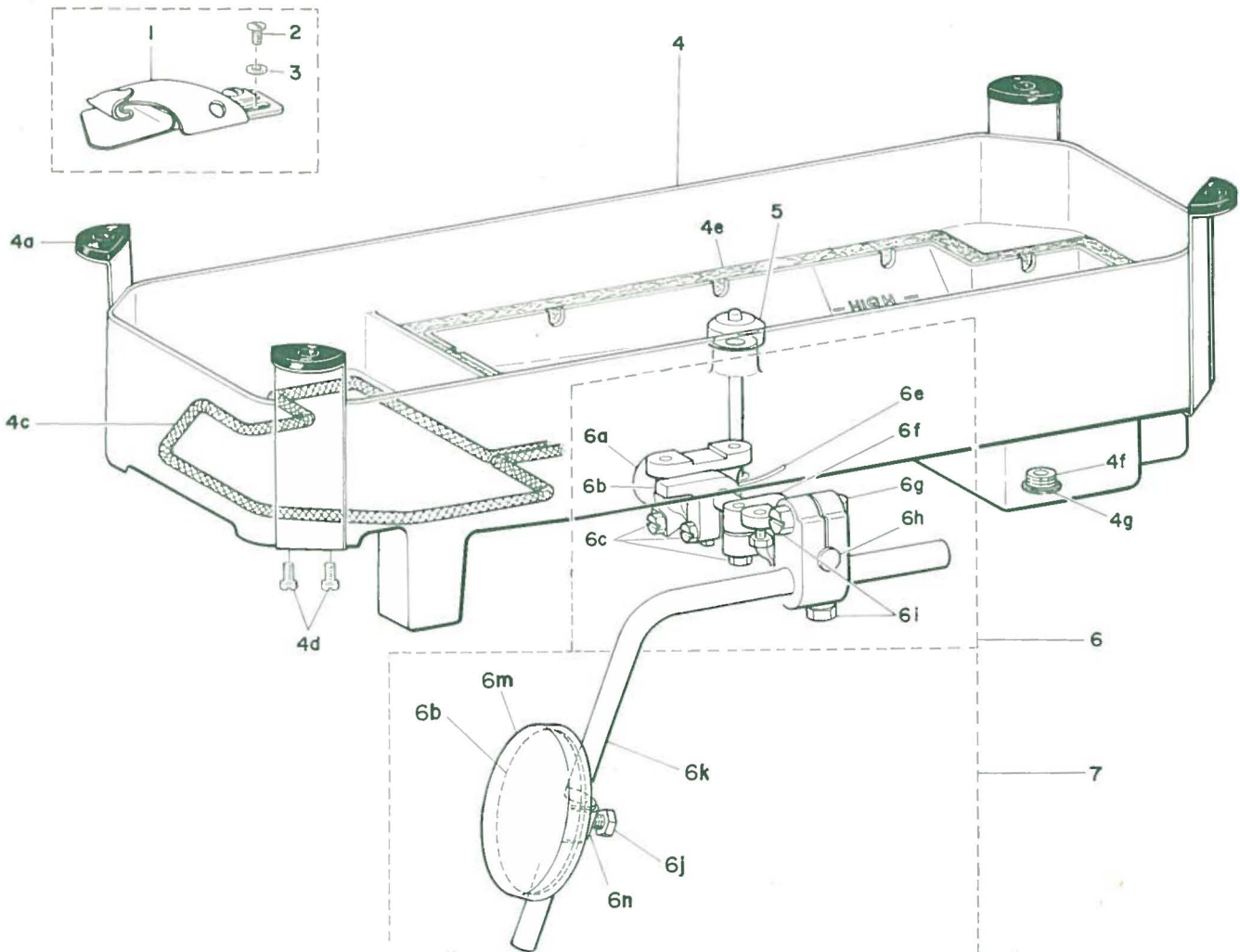

Ref. No.	Part No.	Description	Amt. Req.	Ref. No.	Part No.	Description	Amt. Req.
1	B-9126-038-DAB	Lap seam feller asm. 3/16" MH	1	6g	B-3420-122-000	Knee press rod	①
2	SS-3120540-SP	. . . Screw	2	6h	SS-9182010-SN	. . . Screw	②
3	WP-0501016-SD	. . . Washer	2	*7	B-3419-552-0A0	Knee lifter plate rod asm.	1
5	B-3416-125-0A0	Knee lifter hook asm.	1	6i	SS-9201810-SN	. . . Screw	①
*	B-8127-038-0B0	Oil reservoir complete (No. 4, 6)	1	6k	B-3419-122-000	Knee lifter plate rod	①
4	B-8217-038-0A0	Oil reservoir asm.	1	6d	B-3430-552-000	Knee press plate	①
4a	B-8220-038-0A0	Oil reservoir holder	④	6m	B-3431-552-000	Knee press plate cover	①
4c	B-8226-038-000	Oil wick	①	6n	B-3432-552-000	. . . Stopper	①
4d	SS-6150760-SN	Screw	⑧	6j	SM-9061003-SE	. . . Screw	①
4e	B-8218-038-000	Oil reservoir gasket	①				
4f	SS-6741010-SP	Plug screw	①				
4g	B-8219-125-000	. . . Washer	①				
*6	B-3420-122-0A0	Knee press plate asm.	1				
6a	B-3425-122-000	Knee press lifter lever	①				
6b	B-3426-122-000	Knee press rod thrust block	②				
6c	SS-9182010-SN	. . . Screw	③				
6e	B-3429-122-000	Knee press spring	①				
6f	B-3427-122-000	Knee press rod bearing bracket	①				

12 EXCLUSIVE PARTS FOR MH-38-1 & MH-38-2

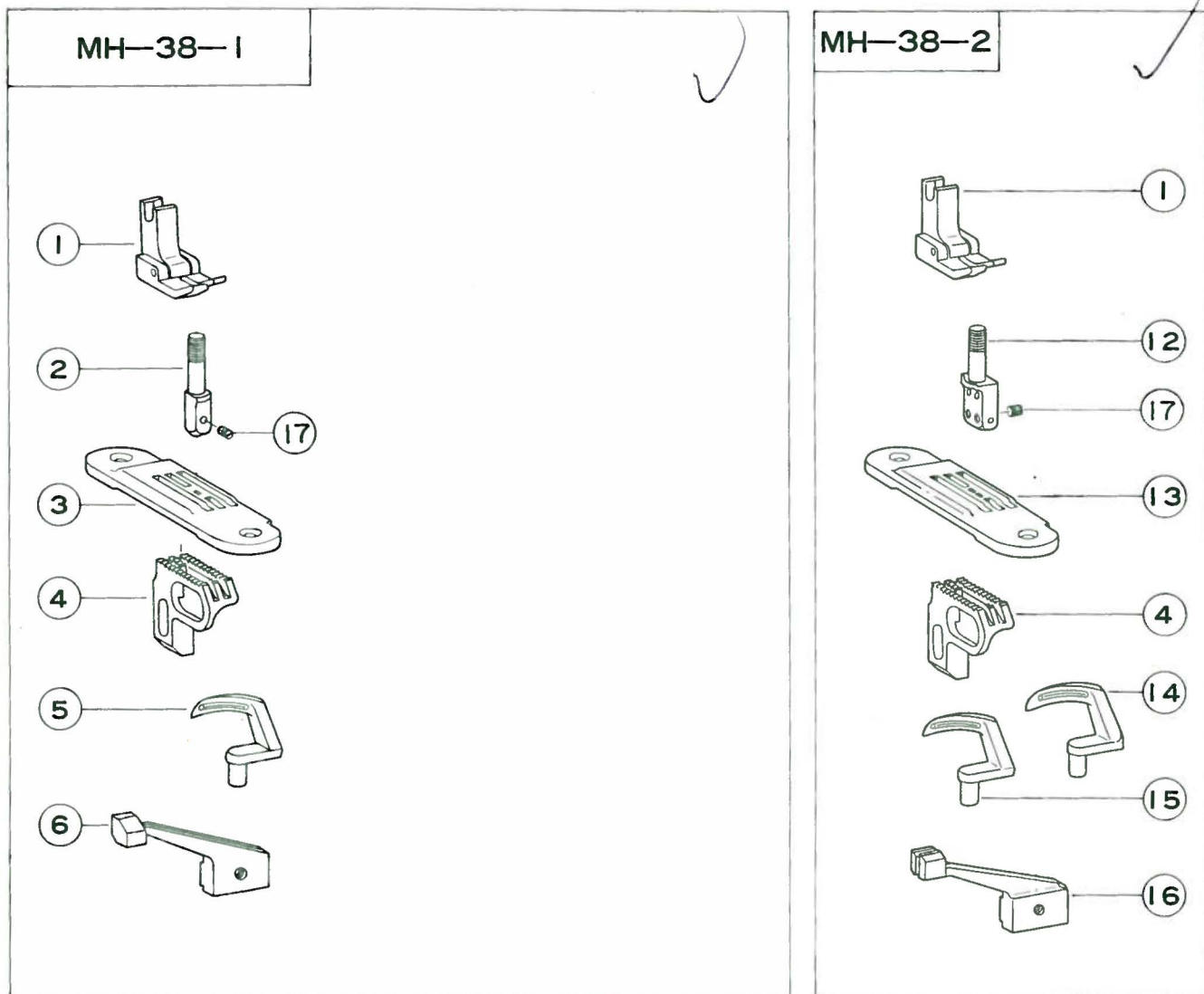

Ref. No.	Part No.	Description	Amt. Req.	Ref. No.	Part No.	Description	Amt. Req.
	*D-1103-038-AF0	Gauge set, for MH-38-1	(1)	14	D-2008-038-B00	Looper (A), for tandem two-needle	1
1	D-1509-038-BA0	Presser foot, for one needle off	1	15	D-2009-038-B00	Looper (B), for tandem two-needle	1
2	D-1406-038-A00	Needle clamp, for one needle off	1	16	D-2117-038-B00	Needle guard, for tandem two-needle	1
17	SS-8110310-SP	Needle set screw	1	17	SS-8110310-SP	Needle set screw	2
3	D-1103-038-A00	Throat plate, for one needle off	1				
4	D-1605-038-B00	Feed dog, for one needle off	1				
5	D-2008-038-A00	Looper, for one needle off	1				
6	D-2117-038-A00	Needle guard, for one needle off	1				
	*D-1103-038-BF0	Gauge set, for MH-38-2	(1)				
1	D-1509-038-BA0	Presser foot, for tandem two-needle	1				
4	D-1605-038-B00	Feed dog, for tandem two-needle	1				
12	D-1406-038-B00	Needle clamp, for tandem two-needle	1				
13	D-1103-038-B00	Throat plate, for tandem two-needle	1				

13. MH-38 GAUGE SETS

NEEDLE GAUGE SYMBOL (•)

1/8" = B ✓ 3/16" = D ✓ 1/4" = F ✓ 3/8" = K
5/32" = C 7/32" = E 5/16" = H 1/2" = L

BINDER SYMBOL

For light weight material = A
For medium-light weight material = B
For heavy weight material = C

On the parts listed below, when ordering the parts with • mark, please specify the symbol for one of the 8 sizes as shown above and for parts with Δ mark, specify the binder symbol for one of the 3 symbols as shown above.

For example: On the part B-1103-038-• F Δ, if you desire size 1/8" for heavy weight materials, please specify as B-1103-038-BFC etc.

B-1103-038-• FO	Gauge set (without binder)
B-1103-038-• FΔ	Gauge set (with binder)
B-1103-038-• 00	Needle plate
B-1605-038-• 00	Feed
B-1509-038-• AO	Presser foot
B-1406-038-• 00	Needle clamp
B-2008-038-• 00	Looper A
B-2009-038-• 00	Looper B
B-9126-038-• AΔ	Binder

(Note) There are no binders available for sizes 5/16", 3/8", 1/2".

For these sizes special needle guides are available.

Binders can be adjusted to the required sewing specifications.

14. NUMERICAL INDEX OF PARTS

Page No.	Page Ref. No.	Page No.	Page Ref. No.	Page No.	Page Ref. No.	Page No.	Page Ref. No.	Page No.	Page Ref. No.
EXCLUSIVE PARTS									
A-1632-007-000	3-35	B-1502-038-000	9-7	B-2101-038-000	5-16	B-3420-122-000	11-6g	B-1406-038-B00	12-12
B-1103-038-D00	2-3	B-1509-581-000	9-1	B-2103-038-000	5-15	B-3420-122-0A0	11-*6	B-1509-038-BA0	12-1
B-1104-038-0A0	2-1	B-1510-581-000	9-2	B-2104-038-000	5-26	B-3425-122-000	11-6a	D-1509-038-BA0	12-1
B-1106-038-000	2-4	B-1505-038-000	9-3	B-2105-038-000	5-17	B-3426-122-000	11-6b	D-1605-038-B00	12-4
B-1106-038-000	2-4	B-1506-038-000	9-4	B-2107-038-000	5-2	B-3427-122-000	11-6f	D-1605-038-B00	12-4
B-1106-122-000	1-14	B-1507-038-0A0	9-14	B-2108-038-000	5-5	B-3429-122-000	11-6e	D-2008-038-A00	12-5
B-1107-038-000	2-10	B-1512-155-000	9-9	B-2109-038-000	5-23	B-3430-552-000	11-6d	D-2008-038-B00	12-14
B-1108-038-000	2-12	B-1601-038-000	6-6	B-2110-038-000	5-8	B-3431-552-000	11-6m	D-2009-038-B00	12-15
B-1109-038-000	2-8	B-1602-038-000	6-19	B-2111-038-000	5-6	B-3432-552-000	11-6n	D-2117-038-A00	12-6
B-1110-038-000	2-7	B-1603-038-000	6-3	B-2112-038-000	5-9	B-3501-122-000	10-28	D-2117-038-B00	12-16
B-1111-012-000	2-5	B-1605-038-D00	6-18	B-2113-038-000	5-4	B-3502-122-000	10-39	NEEDLE	
B-1111-038-000	1-39	B-1606-038-000	6-22	B-2114-038-000	5-38	B-3503-122-000	10-40	MTV-700B1600	8-39
B-1112-038-000	6-36	B-1607-038-000	6-31	B-2115-038-000	5-37	B-3504-155-000	10-41		
B-1113-012-000	6-2	B-1609-038-000	4-17	B-2116-038-000	5-36	B-3506-125-000	10-42	NUT	
B-1113-038-000A	1-29	B-1610-038-0A0	4-14	B-2117-038-000	7-43	B-3507-122-000	10-37	NM-6050540-SP	7-17
B-1114-038-000A	1-30	B-1616-038-000	4-22	B-2118-038-000	7-3	B-3508-038-000	10-30	NS-6080210-SP	6-47
B-1115-038-000	2-35	B-1618-038-0A0	2-38	B-2201-038-000	3-30	B-3509-038-000A	10-14	NS-6090310-SP	3-25
B-1116-038-000	2-39	B-1620-155-000	4-27	B-2202-038-0A0	3-28	B-3511-122-000	10-13	NS-6110310-SP	2-28
B-1117-038-000	1-24	B-1621-038-000	3-41	B-2204-038-000	3-43	B-3512-122-000	10-12	NS-6110310-SP	3-18
B-1118-038-000	1-25	B-1622-038-000	3-39	B-2206-038-000	6-37	B-3517-038-000	10-27	NS-6110402-SP	7-31
B-1119-038-000	3-36	B-1623-552-000	4-21	B-2207-038-000	2-16	B-3520-038-000	10-33	NS-6150310-SP	7-12
B-1121-038-000	3-40	B-1624-552-000	4-19	B-2208-038-000	2-26	B-3521-038-000	10-35	NS-6150310-SP	7-38
B-1123-038-000	1-2	B-1701-038-000	6-43	B-2212-019-000	2-20	B-3523-038-000	10-34	NS-6680410-SP	6-35
B-1124-038-000	1-3	B-1702-038-000	6-11	B-2213-019-000	2-15	B-3526-226-000	10-10	NS-6740510-SP	6-1
B-1134-038-000	6-12	B-1705-038-000	4-23	B-2213-038-000	2-13	B-3527-038-000	10-7	PIN	
B-1164-012-000	1-26	B-1706-038-000	4-33	B-2216-026-000	2-24	B-3528-555-000	10-9		
B-1166-122-000	1-38	B-1707-012-0A0	6-7	B-2301-038-000	3-23	B-3529-226-000	10-8	PT-0252200-S0	8-36
B-1180-541-000	1-1	B-1707-038-000	6-14	B-2303-038-000	3-24	B-3531-155-0A0	10-32	SNAP RING	
B-1201-038-000B	4-6	B-1708-038-000	6-10	B-2306-019-000	3-9	B-3534-155-000	4-39		
B-1203-038-000	4-5	B-1801-038-000	6-28	B-2307-019-000	3-7	B-3536-122-000	10-4	RE-0500000-K0	3-42
B-1204-038-000A	8-37	B-1802-038-000	6-24	B-2310-019-000	3-8	B-3536-155-000	4-1	RUBBER RING	
B-1204-122-000	4-30	B-1803-038-000	6-27	B-2311-019-000	3-3	B-3537-122-000	10-20		
B-1211-038-0A0	8-34	B-1804-038-000	6-34	B-2312-019-000	3-2	B-3545-122-000	10-31	RO-0291801-00	8-42
B-1213-552-000	8-41	B-1806-038-000	6-32	B-2313-019-000	3-4	B-8217-038-0B0	11-*	RO-0442401-00	8-41
B-1214-038-000	4-3	B-1809-038-000	6-25	B-2314-019-000	3-1	B-8217-038-0A0	11-4	RO-1331701-00	4-40
B-1215-552-000	8-43	B-1810-038-000	6-26	B-2315-038-000	9-21	B-8218-038-000	11-4e	RO-1542401-00	4-2
B-1217-092-000	4-41	B-1901-038-000	8-27	B-2316-038-000	9-20	B-8219-125-000	11-4g	HINGE SCREW	
B-1218-012-000	4-10	B-1905-038-000	1-16	B-2317-038-000	9-19	B-8220-038-0A0	11-4a		
B-1224-552-000	8-45	B-1906-019-000	8-18	B-2318-038-000	3-17	B-8226-038-000	11-4c	SD-0260271-SP	4-20
B-1226-552-000	8-44	B-1906-038-000	1-17	B-2319-038-000	3-20	B-9126-038-DAB	11-1	SD-0280401-SL	8-7
B-1233-012-000	4-43	B-1907-038-000	1-19	B-2320-038-000	3-22	OIL TUBE			
B-1235-122-000	4-29	B-1908-019-000	8-5	B-2324-038-000	3-10	BP-3000000-00	10-11	SD-0380551-SL	1-11
B-1301-038-000	4-38	B-1909-038-000	8-4	B-2401-038-000	2-40	BP-3000000-00	10-18	SD-0530221-SD	1-22
B-1302-038-000	4-24	B-1910-019-000	8-6	B-2402-019-000	3-13	BP-3000000-00	10-26	SD-0600301-SP	9-12
B-1303-122-000	4-35	B-1912-038-0A0	1-4A	B-2402-038-000	3-32	BP-3000000-00	10-44	SD-0600401-SP	9-22
B-1305-012-000	4-7	B-1914-038-000	1-8	B-2405-038-0A0	2-*	THRUST COLLAR			
B-1306-012-000	4-26	B-2002-038-000	5-13	B-2405-038-000	2-27	CS-0640863-SH	6-4	SD-0700351-SD	4-13
B-1306-012-000	4-36	B-2004-038-000	5-1	B-2418-019-000	3-31	CS-1031219-SH	6-30	SD-0980401-SD	3-34
B-1307-038-000	4-50	B-2005-038-000	5-12	B-2421-019-000	3-15	CS-1471012-SH	4-9	SD-1020916-SP	6-29
B-1401-155-000	8-10	B-2006-038-000	5-21	B-2623-038-0A0	7-*	OIL WICK			
B-1402-038-000	8-2	B-2011-038-0A0	5-33	B-3126-012-000	3-6	CQ-3030000-00	5-19	SM-6081542-CP	7-15
B-1403-155-000	8-11	B-2014-038-0A0	7-13	B-3132-012-000	3-5	CQ-3030000-00	5-34	SM-9061003-SE	11-6j
B-1405-012-000	8-1	B-2016-038-000	7-16	B-3149-123-A00	1-9	CQ-3030000-00	6-9	CONNECTING SCREW	
B-1406-019-000	8-13	B-2017-038-000	7-14	B-3168-555-B00	2-31	CQ-3030000-00	6-48	SQ-1110402-MZ	7-41
B-1409-019-000	8-28	B-2018-038-0A0	7-18	B-3214-047-000	2-30	CQ-3030000-00	8-16	SQ-1110402-MZ	8-40
B-1411-019-000	5-27	B-2020-038-000	7-23	B-3216-047-000	2-32	CQ-3030000-00	10-15	SQ-1110402-MZ	10-51
B-1411-019-000	8-30	B-2021-038-000	7-22	B-3219-232-000	2-29	CQ-3030000-00	10-17	SQ-1150451-MZ	10-6
B-1412-038-000	8-32	B-2022-038-000	7-19	B-3401-122-0A0	9-29	CQ-3030000-00	10-21	SCREW	
B-1418-019-000	5-28	B-2023-038-000	7-37	B-3404-122-000	9-27	CQ-3030000-00	12-3	SS-2090510-SP	1-10
B-1418-019-000	8-29	B-2026-038-000	7-24	B-3406-125-000	9-15	CQ-3030000-00	12-*	SS-2090510-SP	2-33
B-1419-026-000	5-32	B-2027-038-0A0	7-29	B-3407-155-000	9-24	CQ-3030000-00	12-*	SS-2990510-SP	3-29
B-1419-026-000	8-15	B-2030-038-000	7-30	B-3409-038-000	9-26	EXCLUSIVE PARTS FOR SUBCLASS			
B-1501-038-000	9-6	B-2032-038-000	7-11	B-3416-012-000	9-25	D-1103-038-A00	12-3	SS-2110920-TP	2-2
		B-2035-038-000	10-19	B-3416-125-A00	11-5	D-1103-038-AF0	12-*	SS-3060410-SP	8-17
		B-2036-038-000	7-26	B-3419-122-000	11-6k	D-1103-038-BF0	12-*	SS-3120540-SP	11-2
				B-3419-552-0A0	11-7	D-1103-038-B00	12-13	SS-3150710-SP	9-18
						D-1406-038-A00	12-2	SS-4091010-SP	1-18
								SS-4091010-SP	1-23
								SS-4091010-SP	1-28
								SS-4091010-SP	7-9

Part No.	Page	Ref. No.	Part No.	Page	Ref. No.	Part No.	Page	Ref. No.	Part No.	Page	Ref. No.	
SS-4091010-SP	7-35		SS-7090410-SP	3-11		SS-7111310-SP	7-33		SS-8150310-SP	9-8	SS-9182010-SN	11-6h
SS-4622340-SP	3-21		SS-7090510-SP	2-25		SS-7111410-SP	6-13		SS-8150410-SP	4-28	SS-9201810-SN	11-6j
SS-5060310-SP	8-3		SS-7090510-SP	3-14		SS-7111410-SP	6-16		SS-8150710-SP	4-34		
SS-5060410-SP	3-12		SS-7090510-SP	3-38		SS-7120910-SP	3-33		SS-8150710-SP	5-39	TAPER PIN	
SS-5150540-SP	10-24		SS-7090510-SP	5-18		SS-7120910-SP	8-31		SS-8150710-SP	8-24	TA-0290601-M0	8-19
SS-6060210-SP	2-6		SS-7090510-SP	10-5		SS-7120910-SP	9-30		SS-8151150-SP	4-4	TA-0370301-M0	6-39
			SS-7090520-SP	2-14		SS-7151210-SP	7-1		SS-8151150-SP	4-12	TA-0500601-M0	5-40
SS-6080320-SP	2-9		SS-7090520-SP	2-23		SS-7681650-TP	8-33		SS-8151150-SP	4-31	TA-0570601-M0	4-48
SS-6080320-SP	2-11		SS-7090520-SP	5-22		SS-8080950-SP	9-33		SS-8151150-SP	5-35	TA-0690801-R0	4-32
SS-6080610-TP	10-38		SS-7090520-SP	10-22		SS-8110310-SP	1-40		SS-8151150-SP	6-40	TA-0690801-R0	8-25
SS-6081210-SP	10-43		SS-7090710-SP	1-21		SS-8110310-SP	8-14		SS-8151150-SP	8-26		
SS-6081810-SP	6-20		SS-7090710-SP	2-17		SS-8110310-SP	12-17		SS-8152080-SP	4-42	WASHER	
SS-6090420-SP	1-6		SS-7090910-SP	8-9		SS-8110310-SP	12-17		SS-8620850-SP	6-41	WP-0330500-MB	2-41
SS-6090670-SP	8-8		SS-7091110-SP	2-18		SS-8110320-SP	6-38		SS-8620850-SP	6-41	WP-0371016-SD	1-20
SS-6091510-SP	6-23		SS-7091110-SP	9-10		SS-8110510-SP	5-7		SS-8660610-TP	6-44	WP-0371016-SD	2-19
SS-6092420-SP	6-15		SS-7091410-SP	10-36		SS-8110510-SP	5-11		SS-8660810-TP	4-8	WP-0371016-SP	3-26
SS-6111040-SP	3-16		SS-7110540-SP	5-24		SS-8110510-SP	6-5		SS-8660810-TP	4-25	WP-0480856-SP	6-17
SS-6111040-SP	9-23		SS-7110710-SP	5-25		SS-8110510-SP	6-21		SS-8660810-TP	4-37	WP-0480856-SP	7-40
SS-6111620-SP	6-33		SS-7111110-TP	5-10		SS-8110510-SP	7-5		SS-8660810-TP	4-50	WP-0501016-SD	11-3
SS-6121050-SP	5-3		SS-7111110-TP	5-14		SS-8110510-SP	9-5		SS-8661430-SP	4-15	WP-0621016-SD	7-2
SS-6122030-SP	10-25		SS-7111110-TP	5-20		SS-8110750-SP	2-37		SS-8681650-TP	8-35	WP-0612056-SD	3-37
SS-6150760-SN	11-4d		SS-7111110-TP	7-20		SS-811160-SP	3-19		SS-9111010-SP	7-21	WP-0612516-SD	9-28
SS-6741010-SP	11-4f		SS-7111110-TP	7-39		SS-8150310-SP	6-42		SS-9151440-SP	1-15	WP-0621016-SD	10-23
SS-7080510-SP	6-8		SS-7111120-SP	2-36		SS-8150310-SP	8-12		SS-9182010-SN	11-6c	WP-0651056-SD	9-13



JUKI[®]
TOKYO JUKI INDUSTRIAL CO.,LTD.
Business Office : 23, Kabuki-cho, Shinjuku-ku, Tokyo, Japan
Cable Address : JUKI TOKYO
Telex : 232-2301
Telephone : Tokyo 203-8241

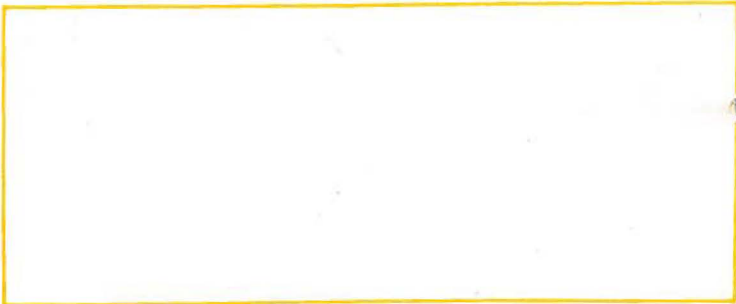

Dr.ch.2347 BJ038BEP Printed in Japan (T)